



O-I Sales and Distribution Netherlands B.V.
 Postbus 46
 3100 AA Schiedam, Netherlands
 Tel. +31 (0) 104094444

CONTAINER & MOULD ENGINEERING
 EUROPE

NOTES:
 THIS DRAWING IS THE PROPERTY OF O-I AND
 MUST NOT BE REPRODUCED OR DISCLOSED
 WITHOUT O-I WRITTEN AUTHORIZATION.

DIMENSIONS EXPRESSED IN mm
 ONLY TOLERANCED DIMENSIONS ARE GUARANTEED.

MANUFACTURING MARKINGS SHOWN ARE FOR ILLUSTRATIVE
 PURPOSES ONLY, ACTUAL MARKINGS ON CONTAINER
 MAY DIFFER, DEPENDANT ON LOCAL LEGISLATION.

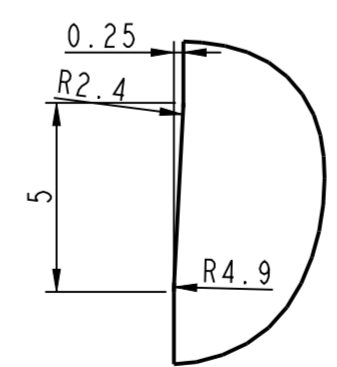
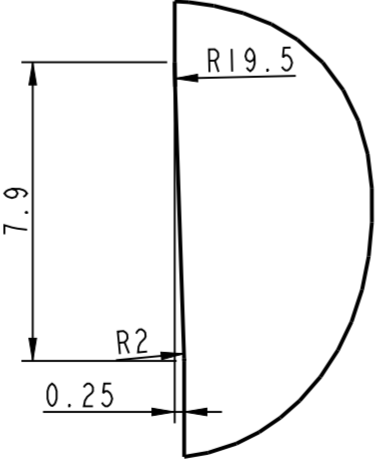
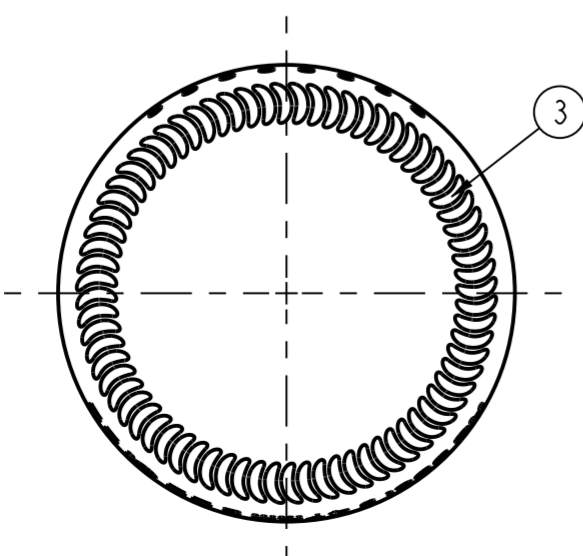
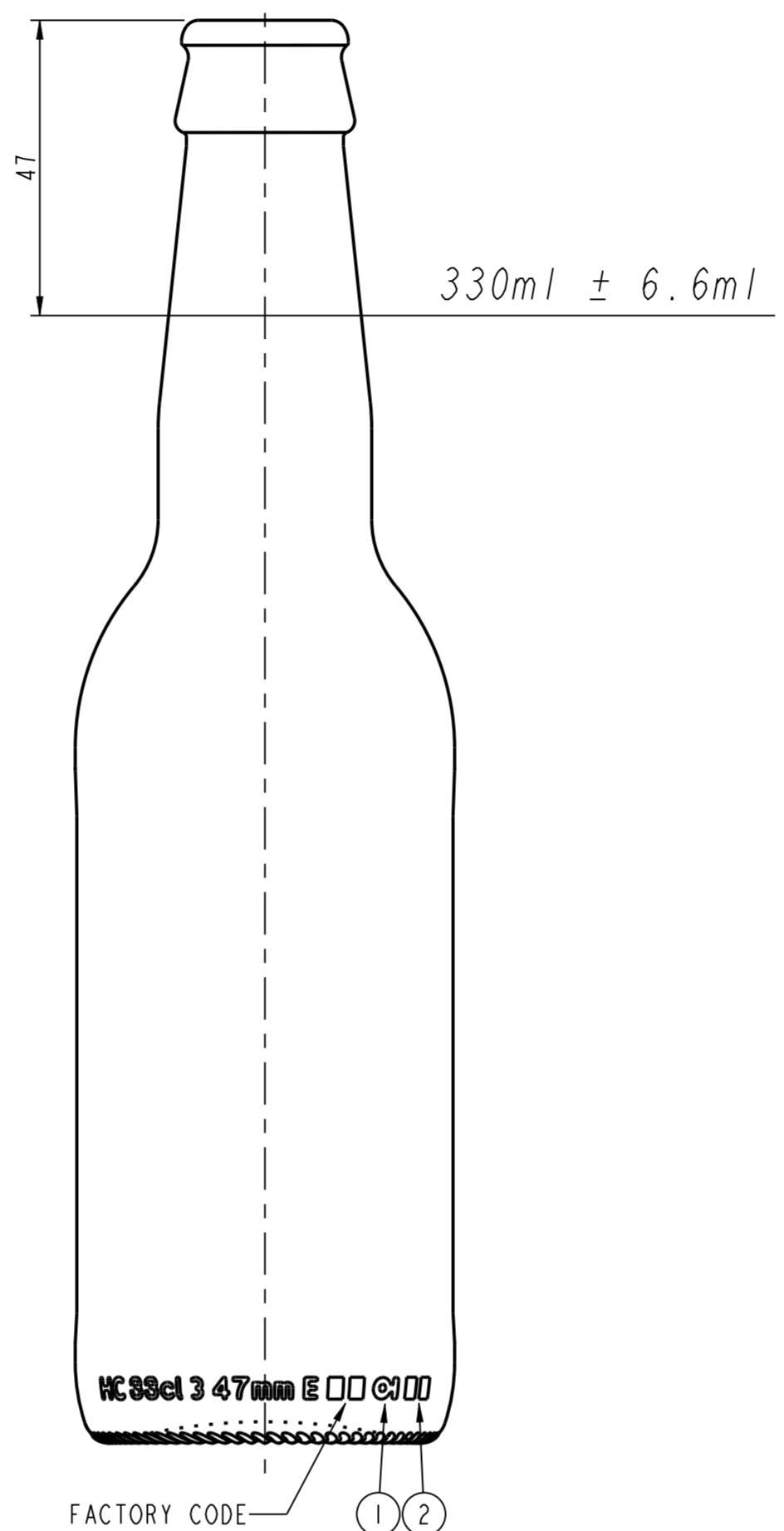
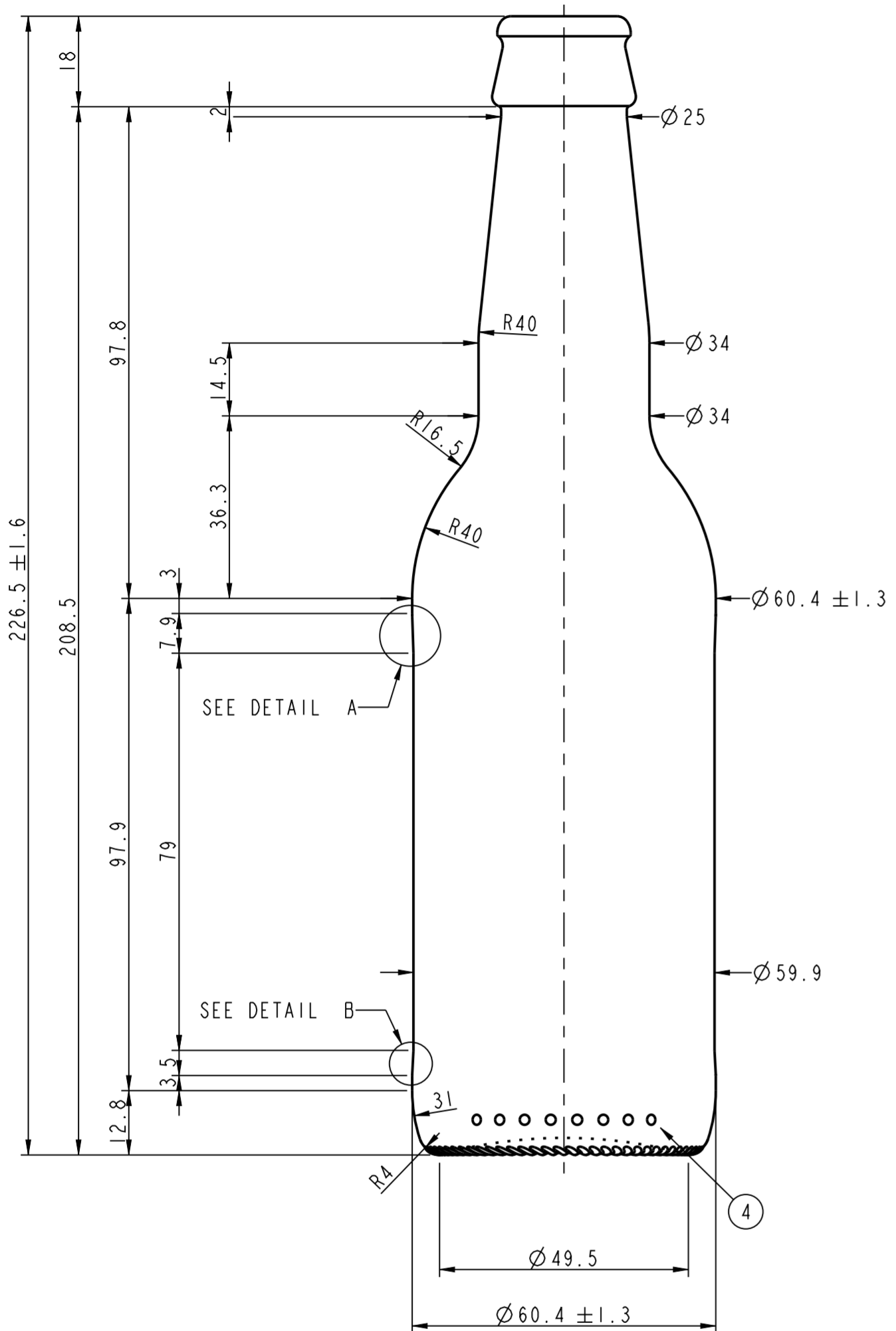

1 = TRADEMARK
 2 = CAVITY No.
 3 = STIPPLING
 THE SHAPE OF STIPPLES IS ONLY AN
 INDICATION AND THE CONSTRUCTION IS AT
 THE PRODUCTION PLANT DISCRETION.
 4 = CAVITY CODE

SCALE 1:1

CORR. FACTOR 1.003

CATEGORY BEER	TILT ANGLE 17.34°
MAX. VERTICALITY TOLERANCE 2.6 mm	MEASURING CONTAINER YES
FINISH SAP NUMBER 0316	FINISH REF. CETIE GME 13.01 2000
MINIMUM THROUGH BORE 16.0 mm	

CONTAINER OVERFLOW CAPACITY (BRIMFUL)	
346ml APPROX.	
CONTAINER RATED CAPACITY (FILLPOINT)	
330ml ± 6.6ml	
CONTAINER WEIGHT	
216g APPROX.	
FINISH DESIGNATION NL_26_GME 13.01_H180_0316	MAX GAS VOLUME 8 g CO2/l
PROCESS NNPB	RETURNABLE NO
DESIGN REF.	

33 cl LN OW HC

DESIGNER	WD	DATE	13/07/17
CHECKED		DATE	
DRAWING NUMBER 170504		MOULD/SAP NUMBER 003268	

No	DATE	REVISIONS	DESIGN/CHECK
2	12-09-19	FINISH DESIGNATION AMENDED	WD
1	01-03-18	HEEL LETTERING AND BOTTLE DISCRPTION AMENDED	WD
	17-07-17	DRAWING UPDATE OF 1447-18 A	WD