

Dolium® 30L S-Spear

PRODUCT NUMBER : 10-30S-02

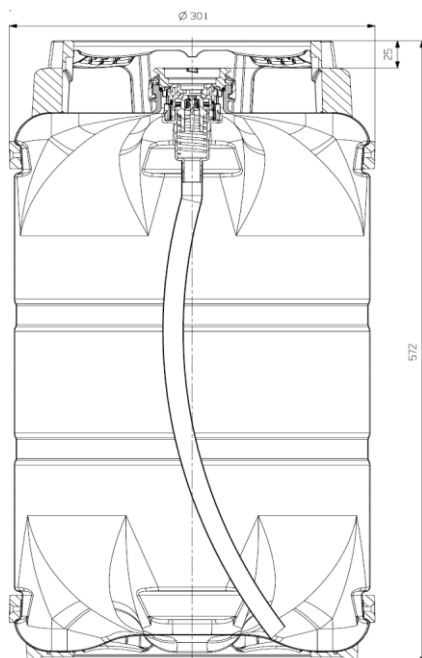
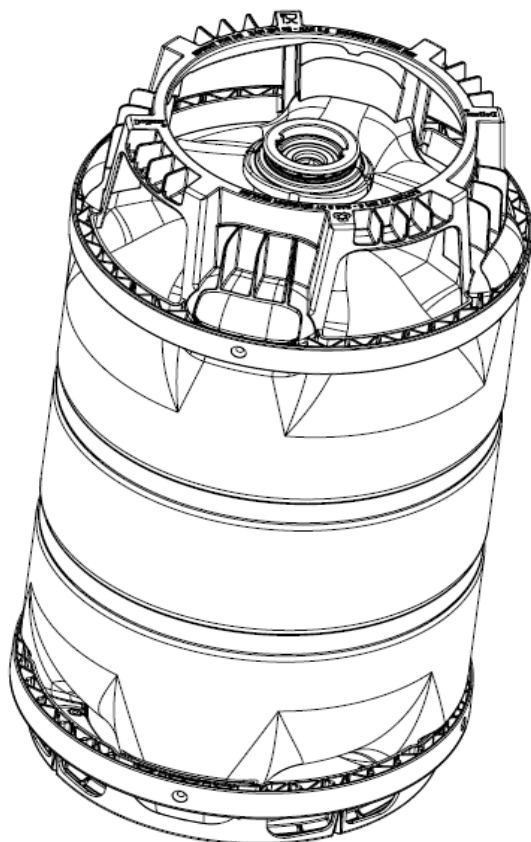

Characteristics

KEG

Type	single use
Volume	30L
Headspace	0,75 L @ 2 bar
Dimensions	D x H = 301 x 572 mm
Weight (empty)	1,20 kg
Temperature	0°C < T < 35°C
Pre- pressure	1,0 bar @ min. 90% CO ₂
Working pressure	3,5 bar max.
Pressure Relief Valve	5,2 bar +/- 0,2
Burst pressure	> 7,0 bar

CONNECTION

Type	Well type (Sankey)
Parts	PET
Spring	Stainless steel Aisi 302
Down tube	LDPE

CONTAINER

PET + active barrier	Invista Polyshield 2300 - monolayer
Passive barrier	Mitsubishi N-MXD6
UV barrier	Toyo - amber

CHIMES

HDPE - high impact resistance - black

APPLICATIONS

Products	Beverages
Shelf life	Equal to stainless steel
Certificates	EU / FDA
Filling line	compatible
Draught installation	compatible
Pallet type (standard)	OW pallet fumigated 1200x800 mm, 1000 kg
Pallet configuration	11 kegs x 4 high - top card + wrapping foil
Stack height empty	247 cm
Stackable empty	3 pallets @ 11 empty kegs x 4 high
Recyclable	100%

for further detailed information please see Handling & Safety instructions

Special features

Contact

Dispack-projects NV

Address: Rostockweg 21, Kaai 312A (AOR - De Schelde)
 Zip code: 2030
 Town: Antwerp
 Country: Belgium

E-mail: info@dolium.eu
 Website: www.dolium.eu