

TECHNICAL SPECIFICATIONS

Doc. Nr.:10BANOMINICL REV 03 ING
04.01.24

WIREHOOD

Revision: 03

Pag.1/1

FINISHED PRODUCT

RAW MATERIAL

CUSTOMER:

ICAS Product code:2301263802FP

Customer Product code:

DIMENSIONAL CHARACTERISTICS

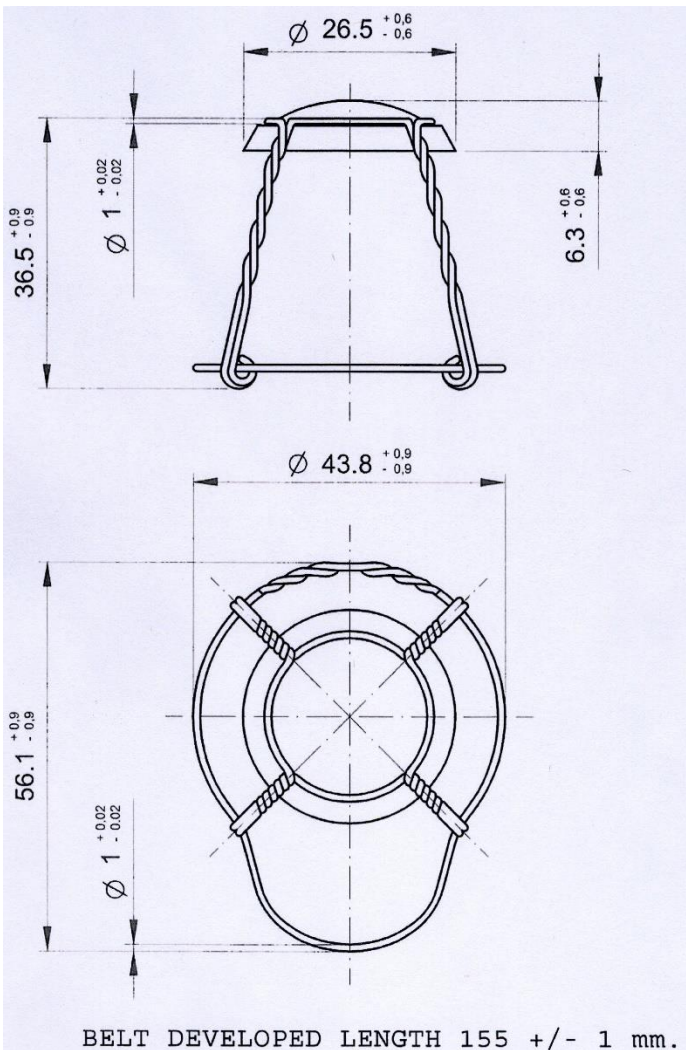

WIREHOOD MINI

FOOD SAFETY

Produced in accordance with GMP (Good Manufacturing Practices);

MATERIAL CODE FOR DISPOSAL: FE 40

Body and belt wire:

• **MATERIAL AND APPLICATION FIELD:**
Galvanized mild steel wire for the production of wirehoods

- **PURITY:** Minimum 99.5% of pure zinc
- **ZINC COATING:** Min. 35g/m²
- **THICKNESS OF LACQUER COAT:** min. 10 μ m
- **DIAMETER:** 1.00 mm \pm 0.02
- **BREAKING POINT:** 320-450 N/mm² (determined according to ISO 6892-1)
- **ELONGATION:** minimum 23% (length of sample: 150 mm/ determined according to ISO 6892-1)
- **TWISTS ON DOUBLE WIRE:** minimum 55 (length of sample: 210 mm)

COLOUR OF THE WIRE: TRANSPARENT

Disc:

- **MATERIAL:** Electrolytic tin-plated metal sheet
- **QUANTITY OF NOMINAL TIN:** 2,8 gr/m²(min. 2,3 gr/m²) on both surfaces
- **HARDNESS OF THE MATERIAL:** scale TS260-TS275
- **THICKNESS:** 0.225 mm \pm 0.01
- **TYPE OF PRINT:** Offset or digital.

Diameter: 30,5 mm

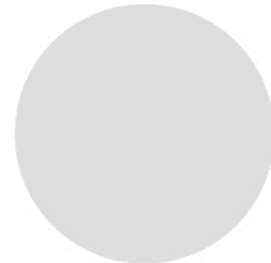

The colors you see are purely indicative

PACKAGING

SPI 44