

Bottom view

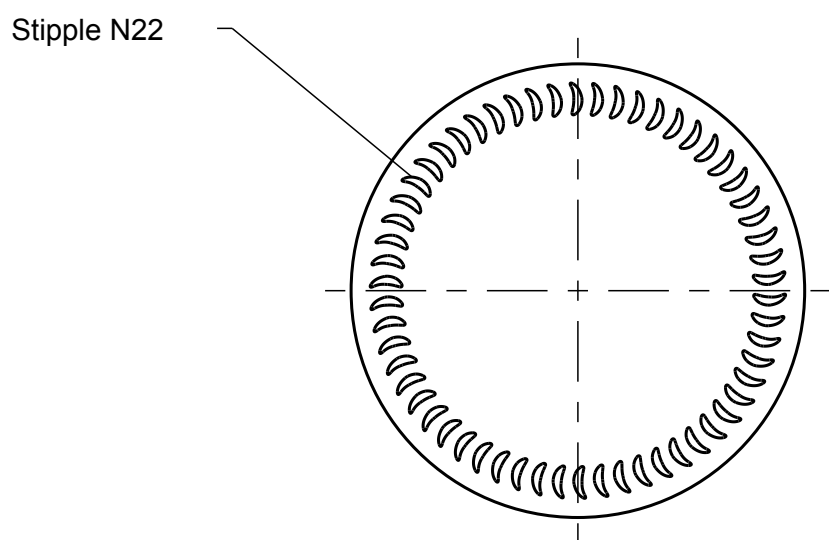

Front view

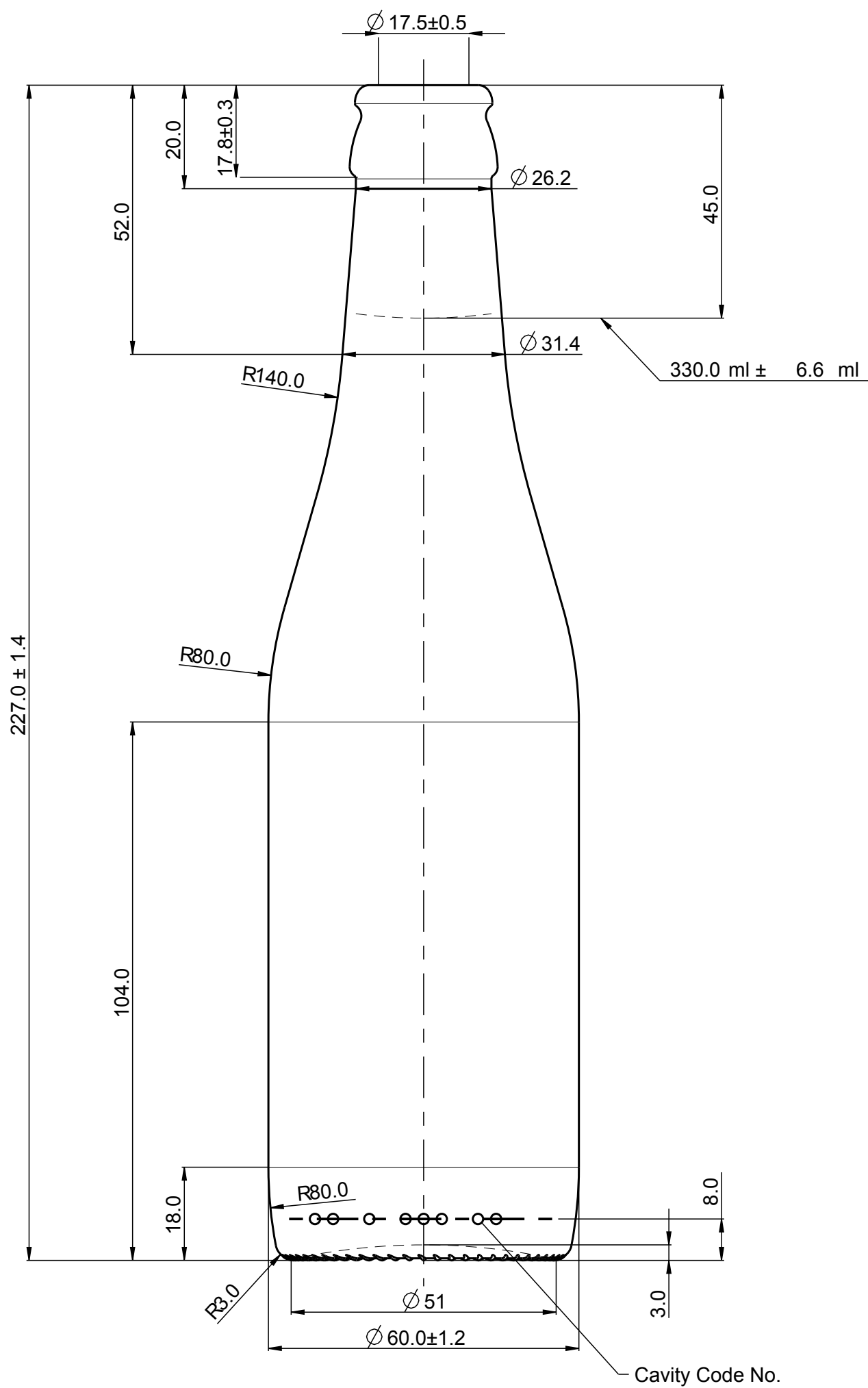

Back view
Developed view of description

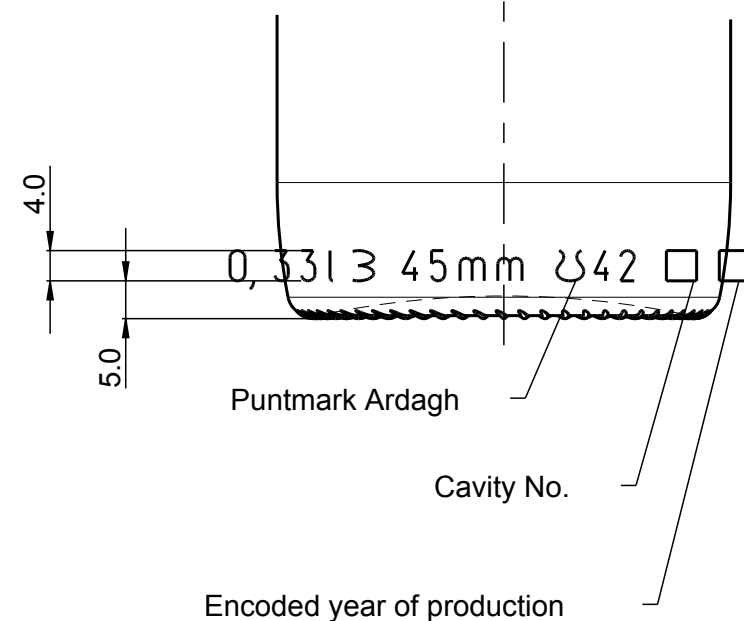

0.4 STIPPLE HEIGHT IS INCLUDED IN ALL DIMENSIONS FROM THE BASE

NOMINAL CAPACITY	330.0 ± 6.6 ml	SPECIFICATION AGREEMENTS ARE BASED ON TOLERANCED DIMENSIONS ONLY DO NOT SCALE DRAWING COPYRIGHT RESERVED, NOT TO BE COPIED IN WHOLE OR PART WITHOUT WRITTEN PERMISSION FROM ARDAGH GLASS LTD. ALL DIMENSIONS ARE IN MILLIMETERS Document supervised by SAP, cProject and Windchill PDMLink systems)				
BRIMFULL CAPACITY	ca 345 ml					
VACUITY	15 ml (4.39 %)		INITIAL DATA	DESIGNER DaumK	SHEET 1 / 1	
FINISH DESCRIPTION / No.	Crown Cork High / Crown Z113		DATE 24.02.2011	CHECKED	SCALE 1:1 (A2)	
MINIMUM THROUGH BORE	16mm		CUSTOMER PROJECT 5276			
WEIGHT NOMINAL	ca 242 g		PRODUCT NAME STD APO OKK_330_C20_27C2			
GLASS COLOUR	Amber C20		DRAWING No. 10475	REVISION A		
USAGE	RETURNABLE		PRODUCT No. SAP CONTAINER No. 31002196			
CARBONATION						
TILT ANGLE	16.0°	A	REVISION	DSG	CHK	DATE