

TECHNICAL SPECIFICATIONS FOR THE 26 MM PRY OFF CROWN CAP

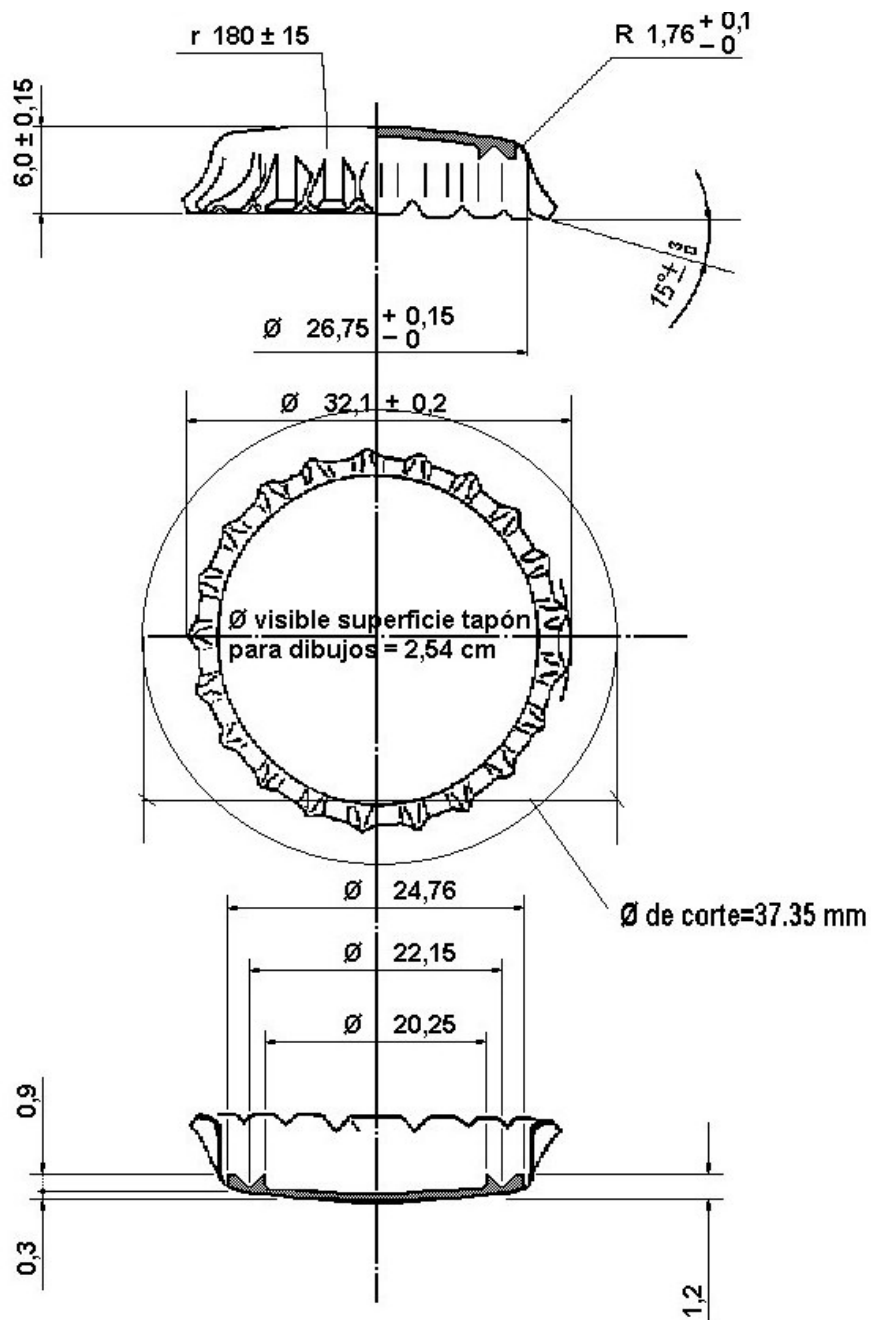

1. Material

Product	ETP		TFS	
Temper:	0.22 mm TH 435 0.22 <thickness<0.25 TH415 Rockwell (61 ± 4 HR 30T)	0.20 ± 0.02 mm TH 460 Rockwell (61 ± 4 HR 30T)	0.22 mm TH 435 0.22 <thickness<0.25 TH415 Rockwell (61 ± 4 HR 30T)	0.20 ± 0.02 mm TH 460 Rockwell (61 ± 4 HR 30T)
Coating protection on the steel sheet:	Tin coat: 2.8/2.8 grs/m ² (E1/E1)		Chrome coat: 50 – 140 mg/m ²	

2. Shell dimension

Crown internal diameter d1 + 0,15	Crown external diameter d2 ± 0,2	Crown Height h ± 0,15	Radius r ± 15	Metal thickness ± 0,02	N° teeth
26,75	32,1	6	180	0.22-025 0.20	21

Total weight: 0,22 mm (2 g +/- 8%)

Metal Finish: Stone

3. Liner

- Type: PVC free or Oxygen Scavenger (Svelon, Svelox)
- Based in low density polyethylene (LDPE)
Ethylene cas number 74-85-01 EC Number 200-815-3

4. Inks & Varnishes

- Inside: BPANI interior varnish (PVC Free)
- Outside:
 - One of two options: Enamel / Base varnish: Polyester BPANI
 - INKS
 - Over print varnish: Polyester BPANI

5. Use

- Suitable for closing bottles according UNE 126-401-92 or similar. For use on mineral water, carbonated soft drinks, beer and fruit juices.
- Pasteurisation resistant (approx. 20 min. at 62°C) and hot fill (Approx. 70°C with cooling).
- Recommended crimping diameter*: 28,57 ÷ 28,83 mm, at a total force of 400 kp (closing “cone” diameter 28,2-28,3mm). *28,57 ÷ 28,96 mm is also approved if the machines requires it.

- Internal pressure retention: min. 7 bar.
- Food grade: EU and FDA compliant.

Closure application and performances should be verified on a case by case basis, as the capping is a function of both the bottle neck (design and consistency), the specific closing equipment used (closing tools, capping loads), and thermal treatments (pasteurization).

6. Warehouse

The crown corks should be kept in their boxes, sealed, in a covered and ventilated place, sheltered from direct sunlight and moisture and away from sources of odors that could be transmitted to the crown cork (storage conditions: >15°C, < 30°C). The crown stored in this condition, have a shelf life of one year.

7. Boxes

10.000 - 10.500 units / box